



# Leon County

## Board of County Commissioners

301 South Monroe Street, Tallahassee, Florida 32301  
(850) 606-5302 www.leoncountyfl.gov

Purchasing Division  
2284 Miccosukee Road  
Tallahassee, Florida 32308  
(850) 606-1600

Commissioners

BILL PROCTOR  
District 1

JANE G. SAULS  
District 2

JOHN DAILEY  
District 3

BRYAN DESLOGE  
District 4

BOB RACKLEFF  
District 5

CLIFF THAELL  
At-Large

AKIN AKINYEMI  
At-Large

PARWEZ ALAM  
County Administrator

HERBERT W.A. THIELE  
County Attorney

February 11, 2010

RE: Dr. B. L. Perry Branch Library Expansion  
Bid No: BC-02-24-10-18  
Opening Date: Wednesday, February 24, 2010 at 2:00 PM

### ADDENDUM # 4

Dear Vendor:

This letter serves as Addendum #4 for the above referenced project.

Attached is Amendment #4 from the Architect which shall become a part fo the Contract Documents.

Acknowledgment of this addendum is required as part of your bid submittal. Failure to acknowledge this addendum may result in rejection of your bid.

Should you have any questions, feel free to call me at (850) 606-1600.

Sincerely,

A handwritten signature in black ink, appearing to read "Keith M. Roberts".

Keith M. Roberts  
Purchasing Director

KMR

## **ADDENDUM #4**

Leon County Florida

### **DR. BL PERRY BRANCH LIBRARY EXPANSION**

Tallahassee, Florida

**11 February 2010**

---

#### **GENERAL**

This addendum becomes part of the Contract Documents. Bidders shall note receipt of this addendum in the appropriate space on the Bid Form.

Bids are due on Wednesday 24 February 2010 at 02:00 PM EST.

---

#### **TECHNICAL**

Below are descriptions of revisions to documents contained in Addendum #4 dated 11 February 2010:

##### **Revisions to Specifications:**

Item No. 1: Refer to attached revised Table of Contents for the following revisions:

- a: Added specification section 06 4020 - Interior Architectural Woodwork
- b: Added entry for specification section 07 4113 - Metal Roof Panels  
(section is in the specs but was inadvertently omitted from the Table of Contents)
- c: Revised title for specification section 072413 - Exterior Finish System to  
072413 - Polymer-based Exterior Insulation and Finish System.

Item No. 2: Added specification section 06 4020 Interior Architectural Woodwork.

Item No. 3: Revised specification section 072413 - Polymer-based Exterior Insulation and Finish System.

##### **Revisions to Drawings:**

Item No. 4: Refer to attached revised drawing sheet A5.1 revision 1 dated 11 February 2010 for the following revisions:

- a: Added new section 8/A5.1
- b: Revised detail 4/A5.1

Item No. 5: Refer to attached supplemental drawing SD-1 dated 11 February 2010 for the following:

- a: Added new reference tag 8/A5.1 in building section 2/A4.1

**END OF ADDENDUM #4**

**TABLE OF CONTENTS**  
**DR. B.L. PERRY JR.**  
**BRANCH LIBRARY BUILDING**  
**TALLAHASSEE, FLORIDA**

Cover Page  
Table of Contents

**DIVISION 1 - GENERAL REQUIREMENTS**

- 011000 - Summary
- 01300 - Submittals
- 01340 - Shop Drawings, Product Data and Samples
- 01400 - Quality Control Services
- 01410 - Quality Control Services - Testing Adjusting, and Balancing –  
Division 15000, Mechanical
- 017320 - Selective Demolition
- 017700 - Closeout Procedures

**DIVISION 2 - EXISTING CONDITIONS**

- 02110 - Demolition Clearing and Grubbing
- 02200 - Earthwork
- 02210 - Site Grading
- 02221 - Trenching, Backfilling, & Compaction
- 02276 - Erosion & Sedimentation Control
- 02513 - Asphaltic Concrete Pavement
- 02515 - Concrete Curb & Gutter
- 02721 - Storm Sewer System

**DIVISION 3 - CONCRETE**

- 03100 - Concrete Formwork
- 03200 - Concrete Reinforcement
- 03300 - Cast-In-Place Concrete

**DIVISION 4 - MASONRY**

- 042200 - Concrete Unit Masonry
- 04230 - Reinforced Masonry

**DIVISION 5 - METALS**

- 05120 - Structural Steel
- 05300 - Steel Deck

05400 - Cold-Formed Metal Framing

## **DIVISION 6 - WOOD AND PLASTIC**

061050 - Miscellaneous Carpentry

064020 - Interior Architectural Woodwork (*Added 11 February 2010*)

## **DIVISION 7 - THERMAL AND MOISTURE PROTECTION**

07210 - Thermal Insulation

072413 - Polymer-Based Exterior Insulation and  
Finish System (EIFS) (*Revised 11 February 2010*)

074113 - Metal Roof Panels

079200 - Joint Sealants

## **DIVISION 8 - DOORS AND WINDOWS**

081100 - Steel Doors and Frames

084113 - Aluminum-Framed Entrances and Storefronts

087100 - Door Hardware

088000 - Glazing

## **DIVISION 9 - FINISHES**

092550 - Gypsum Board Assemblies

093000 - Tiling

095110 - Acoustical Panel Ceilings

096513 - Resilient Base and Accessories

096800 - Carpet

099120 - Painting (Professional Line Products)

## **DIVISION 10 - SPECIALTIES**

105200 - Fire-Protection Specialties

## **DIVISION 15 – MECHANICAL**

15010 - Mechanical General Provisions

15015 - Submittals

15043 - Testing, Adjusting and Balancing

15047 - Identification

15160 - Vibration Isolation

15180 - Insulation – General

15190 - Insulation – External Duct

15193 - Firestop Systems

15840 - Ductwork, Louvers, and Accessories

15844 - Cleaning of Air Conveyance Systems

15860 - Diffusers, Grilles and Registers

- 15865 - Variable Air Volume Terminal Units
- 15880 - Air Filters
- 15900 - Building Automation System

## **DIVISION 16 – ELECTRICAL**

- 16010 - Electrical General Provisions
- 16012 - Summary of Electrical Work
- 16015 - Submittals
- 16030 - Grounding
- 16047 - Identification
- 16110 - Raceways
- 16120 - Insulated Conductors
- 16130 - Boxes
- 16140 - Wiring Devices
- 16445 - Panelboards – Distribution and Branch Circuit
- 16510 - Lighting Fixtures and Lamps
- 16709 - Surge Suppression Devices
- 16776 - Telephone/Data System Raceways

## SECTION 064020 - INTERIOR ARCHITECTURAL WOODWORK

### PART 1 - GENERAL

#### 1.1 RELATED DOCUMENTS

- A. Drawings and general provisions of the Contract, including General and Supplementary Conditions and Division 1 Specification Sections, apply to this Section.

#### 1.2 SUMMARY

- A. This Section includes the following:
  - 1. Laminate-clad cabinets (plastic-covered casework).
  - 2. Plastic-laminate countertops.
- B. Related Sections: The following Sections contain requirements that relate to this Section:
  - 1. Division 8 Section "Flush Wood Doors" for doors specified by reference to architectural woodwork standards.

#### 1.3 DEFINITIONS

- A. Interior architectural woodwork includes wood furring, blocking, shims, and hanging strips for installing woodwork items unless concealed within other construction prior to woodwork installation.

#### 1.4 SUBMITTALS

- A. General: Submit each item in this Article according to the Conditions of the Contract and Division 1 Specification Sections.
- B. Product data for each type of product and process specified and incorporated into items of architectural woodwork during fabrication, finishing, and installation.
- C. Shop drawings showing location of each item, dimensioned plans and elevations, large-scale details, attachment devices, and other components.
  - 1. Show details full size.
  - 2. Show locations and sizes of furring, blocking, and hanging strips, including concealed blocking and reinforcing specified in other Sections.
  - 3. Show locations and sizes of cutouts and holes for plumbing fixtures, faucets, soap

dispensers, and other items installed in architectural woodwork.

- D. Samples for initial selection of the following in the form of manufacturer's color charts consisting of actual units or sections of units showing the full range of colors, textures, and patterns available for each type of material indicated.
  - 1. Plastic laminates.
- E. Samples for verification of the following:
  - 1. Laminate-clad panel products, 8 by 10 inches (200 by 250 mm), for each type, color, pattern, and surface finish, with separate samples of unfaced panel product used for core.
- F. Product certificates signed by woodwork fabricator certifying that products comply with specified requirements.

#### 1.5 QUALITY ASSURANCE

- A. Fabricator Qualifications: Firm experienced in producing architectural woodwork similar to that indicated for this Project and with a record of successful in-service performance, as well as sufficient production capacity to produce required units without delaying the Work.
- B. Installer Qualifications: Arrange for interior architectural woodwork installation by a firm that can demonstrate successful experience in installing architectural woodwork items similar in type and quality to those required for this Project.
- C. Single-Source Responsibility for Fabrication and Installation: Engage a qualified woodworking firm to assume undivided responsibility for fabricating, finishing, and installing woodwork specified in this Section.
- D. Quality Standard: Except as otherwise indicated, comply with the following standard:
  - 1. AWI Quality Standard: "Architectural Woodwork Quality Standards" of the Architectural Woodwork Institute for grades of interior architectural woodwork, construction, finishes, and other requirements.
    - a. Provide AWI Certification Labels or Certificates of Compliance indicating that woodwork meets requirements of grades specified.
  - 2. The Contract Documents contain selections chosen from options in the Quality Standard as well as additional requirements beyond those of the Quality Standard. Comply with such selections and requirements in addition to the Quality Standard.
  - 3. Surface-Burning Characteristics: Not exceeding values indicated below, tested per ASTM E 84 for standard time period (10 minutes).



- a. Flame Spread: 75.
- b. Smoke Developed: 450.

#### 1.6 DELIVERY, STORAGE, AND HANDLING

- A. Protect woodwork during transit, delivery, storage, and handling to prevent damage, soilage, and deterioration.
- B. Do not deliver woodwork until painting and similar operations that could damage, soil, or deteriorate woodwork have been completed in installation areas. If woodwork must be stored in other than installation areas, store only in areas whose environmental conditions meet requirements specified in "Project Conditions."

#### 1.7 PROJECT CONDITIONS

- A. Environmental Limitations: Do not deliver or install woodwork until building is enclosed, wet-work is completed, and HVAC system is operating and will maintain temperature and relative humidity at occupancy levels during the remainder of the construction period.
- B. Environmental Limitations: Obtain and comply with woodwork fabricator's and Installer's coordinated advice for optimum temperature and humidity conditions for woodwork during its storage and installation. Do not install woodwork until these conditions have been attained and stabilized so that woodwork will be within plus or minus 1.0 percent of optimum moisture content from date of installation through remainder of construction period.
- C. Field Measurements: Where woodwork is indicated to be fitted to other construction, check actual dimensions of other construction by accurate field measurements before fabrication, and show recorded measurements on final shop drawings. Coordinate fabrication schedule with construction progress to avoid delaying the Work.
  - 1. Verify locations of concealed framing, blocking, reinforcements, and furring that support woodwork by accurate field measurements before being enclosed. Record measurements on final shop drawings.
  - 2. Where field measurements cannot be made without delaying the Work, guarantee dimensions and proceed with fabricating woodwork without field measurements. Provide allowance for trimming at site and coordinate construction to ensure that actual dimensions correspond to guaranteed dimensions.

#### 1.8 COORDINATION

- A. Coordinate sizes and locations of framing, blocking, furring, reinforcements, and other related units of Work specified in other Sections to ensure that interior architectural woodwork can be supported and installed as indicated.

- B. Hardware Coordination: Distribute copies of approved schedule for cabinet hardware specified in Division 8 Section "Door Hardware" to fabricator of architectural woodwork; coordinate cabinet shop drawings and fabrication with hardware requirements.

## PART 2 - PRODUCTS

### 2.1 MATERIALS

- A. General: Provide materials that comply with requirements of the AWI quality standard for each type of woodwork and quality grade indicated and, where the following products are part of interior woodwork, with requirements of the referenced product standards that apply to product characteristics indicated:
- B. Particleboard: ANSI A208.1, Grade M-2 made with phenol-formaldehyde resins.
- C. High-Pressure Decorative Laminate: NEMA LD 3, grades as indicated, or if not indicated, as required by woodwork quality standard.
  - 1. Manufacturer: Subject to compliance with requirements, provide high-pressure decorative laminates by one of the following:
    - a. Formica Corporation.
    - b. Laminart.
    - c. Nevamar Corp.
    - d. Pioneer Plastics Corp.
    - e. Westinghouse Electric Corp.; Specialty Products Div.
    - f. Ralph Wilson Plastics Co.
- D. Adhesive for Bonding Plastic Laminate: Contact cement.
- E. Thermoset Decorative Overlay: Decorative surface of thermally fused polyester or melamine-impregnated web, bonded to specified substrate and complying with ALA 1992.
  - 1. Substrate: Medium-density particleboard.

### 2.2 CABINET HARDWARE AND ACCESSORY MATERIALS

- A. Cabinet Hardware Schedule: Refer to schedule at end of this Section for cabinet hardware required for architectural cabinets.

### 2.3 INSTALLATION MATERIALS

- A. Furring, Blocking, Shims, and Hanging Strips: Softwood or hardwood lumber, kiln dried to less than 15 percent moisture content.

- B. Screws: Select material, type, size, and finish required for each use. Comply with ASME B18.6.1 for applicable requirements.
  - 1. For metal framing supports, provide screws as recommended by metal-framing manufacturer.
- C. Nails: Select material, type, size, and finish required for each use. Comply with FS FF-N-105 for applicable requirements.
- D. Anchors: Select material, type, size, and finish required for each substrate for secure anchorage. Provide nonferrous metal or hot-dip galvanized anchors and inserts on inside face of exterior walls and elsewhere as required for corrosion resistance. Provide toothed steel or lead expansion bolt devices for drilled-in-place anchors.

#### 2.4 FABRICATION, GENERAL

- A. Interior Woodwork Grade: Provide interior woodwork complying with the referenced quality standard and of the following grade:
  - 1. Grade: Premium.
- B. Wood Moisture Content: Comply with requirements of referenced quality standard for wood moisture content in relation to relative humidity conditions existing during time of fabrication and in installation areas.

#### 2.5 LAMINATE-CLAD CABINETS (PLASTIC-COVERED CASEWORK)

- A. Quality Standard: Comply with AWI Section 400 requirements for laminate-clad cabinets.
  - 1. Grade: Premium.
- B. AWI Type of Cabinet Construction: Flush overlay.
- C. Laminate Cladding for Exposed Surfaces: High-pressure decorative laminate complying with the following requirements:
  - 1. Horizontal Surfaces Other than Tops: GP-50, 0.050-inch (1.270-mm) nominal thickness.
  - 2. Vertical Surfaces: GP-50, 0.050-inch (1.270-mm) nominal thickness.

3. Edges: GP-50, 0.050-inch (1.270-mm) nominal thickness.

- D. Materials for Semiexposed Surfaces: Provide surface materials indicated below:
  - 1. Surfaces Other than Drawer Bodies: High-pressure decorative laminate, Grade GP-

28.

2. Drawer Sides and Backs: Thermoset decorative overlay.
3. Drawer Bottoms: Thermoset decorative overlay.

E. Colors, Patterns, and Finishes: Provide materials and products that result in colors and textures of exposed laminate surfaces complying with the following requirements:

1. Refer to finish plans' legend for finishes in the following categories:
  - a. Colors according to Finish Schedule.

## 2.6 COUNTERTOPS

A. Quality Standard: Comply with AWI Section 400 requirements for countertops.

1. Grade: Premium.

B. Type of Top: High-pressure decorative laminate complying with the following:

1. Grade: GP-50, 0.050-inch (1.270-mm) nominal thickness.
2. Colors, Patterns, and Finishes: Provide materials and products that result in colors and textures of exposed laminate surfaces complying with the following requirements:
  - a. Provide colors as referenced in laminate-clad cabinets.
3. Edge Treatment: Same as laminate cladding on horizontal surfaces.
4. Core Material: Exterior-grade plywood.

## PART 3 - EXECUTION

### 3.1 PREPARATION

- A. Condition woodwork to average prevailing humidity conditions in installation areas before installing.
- B. Before installing architectural woodwork, examine shop-fabricated work for completion and complete work as required, including back priming and removal of packing.

### 3.2 INSTALLATION

- A. Quality Standard: Install woodwork to comply with AWI Section 1700 for the same grade specified in Part 2 of this Section for type of woodwork involved.
- B. Install woodwork plumb, level, true, and straight with no distortions. Shim as required with concealed shims. Install to a tolerance of 1/8 inch in 96 inches (3 mm in 2400 mm) for plumb and level (including tops).
- C. Scribe and cut woodwork to fit adjoining work and refinish cut surfaces or repair damaged finish at cuts.
- D. Anchor woodwork to anchors or blocking built in or directly attached to substrates. Secure to grounds, stripping and blocking with countersunk, concealed fasteners and blind nailing as required for complete installation.
- E. Cabinets: Install without distortion so that doors and drawers fit openings properly and are accurately aligned. Adjust hardware to center doors and drawers in openings and to provide unencumbered operation. Complete the installation of hardware and accessory items as indicated.
  - 1. Install cabinets with no more than 1/8 inch in 96-inch (3 mm in 2400-mm) sag, bow, or other variation from a straight line.
- F. Tops: Anchor securely to base units and other support systems as indicated. Calk space between backsplash and wall with specified sealant.
  - 1. Install countertops with no more than 1/8 inch in 96-inch (3 mm in 2400-mm) sag, bow, or other variation from a straight line.

### 3.3 ADJUSTING AND CLEANING

- A. Repair damaged and defective woodwork where possible to eliminate functional and visual defects; where not possible to repair, replace woodwork. Adjust joinery for uniform appearance.
- B. Clean, lubricate, and adjust hardware.
- C. Clean woodwork on exposed and semiexposed surfaces. Touch up shop-applied finishes to restore damaged or soiled areas.

### 3.4 PROTECTION

- A. Provide final protection and maintain conditions in a manner acceptable to fabricator and Installer that ensures that woodwork is without damage or deterioration at the time of Substantial Completion.

### 3.5 CABINET HARDWARE AND ACCESSORY SCHEDULE

- A. BHMA numbers are used below to designate hardware requirements, except as otherwise indicated.
- B. Concealed (European Type) Hinges: Blum Model 90
- C. Pulls: Forms and Surfaces; HC 110 nylon pulls or equal, color to be selected by Architect.
- D. Shelf Rests: Knape and Vogt, 332 Series, anochrom finish.
- E. Drawer Slides: Side-mounted, full-extension, zinc-plated steel drawer slides with steel ball bearings, complying with BHMA A156.9, Grade 1 and rated for the following loads:
  - 1. Box Drawer Slides: Knape and Vogt, 8300 Series, 75 lb. load rating

END OF SECTION 064020

# SECTION 072413 - POLYMER-BASED EXTERIOR INSULATION AND FINISH SYSTEM (EIFS)

## PART 1 - GENERAL

### 1.1 RELATED DOCUMENTS

- A. Drawings and general provisions of the Contract, including General and Supplementary Conditions and Division 1 Specification Sections, apply to this Section.

### 1.2 SUMMARY

- A. Section Includes:
  - 1. Exterior insulation and finish system (EIFS) applied over masonry and exterior cement board.

### 1.3 SYSTEM DESCRIPTION

- A. Class PB EIFS: A non-load-bearing, exterior wall cladding system that consists of an insulation board attached adhesively, mechanically, or both to the substrate; an integrally reinforced base coat; and a textured protective finish coat.

### 1.4 PERFORMANCE REQUIREMENTS

- A. EIFS Performance: Comply with the following:
  - 1. Bond Integrity: Free from bond failure within EIFS components or between system and supporting wall construction, resulting from exposure to fire, wind loads, weather, or other in-service conditions.
  - 2. Weathertightness: Resistant to water penetration from exterior into EIFS and assemblies behind it or through them into interior of building that results in deterioration of thermal-insulating effectiveness or other degradation of EIFS and assemblies behind it, including substrates, supporting wall construction, and interior finish.
- B. Class PB EIFS: Provide EIFS having physical properties and structural performance that comply with the following:

1. Abrasion Resistance: Sample consisting of 1-inch- (25.4-mm-) thick EIFS mounted on 1/2-inch- (12.7-mm-) thick gypsum board; cured for a minimum of 28 days; and showing no cracking, checking, or loss of film integrity after exposure to 528 quarts (500 L) of sand when tested per ASTM D 968, Method A.
2. Absorption-Freeze Resistance: No visible deleterious effects and negligible weight loss after 60 cycles per EIMA 101.01.
3. Accelerated Weathering: Five samples per ICC-ES AC219 showing no cracking, checking, crazing, erosion, rusting, blistering, peeling, delamination, or other characteristics that might affect performance as a wall cladding after testing for 2000 hours when viewed under 5 times magnification per ASTM G 154 or ASTM G 155.
4. Freeze-Thaw: No surface changes, cracking, checking, crazing, erosion, rusting, blistering, peeling, or delamination, or indications of delamination between components when viewed under 5 times magnification after 60 cycles per EIMA 101.01.
5. Mildew Resistance of Finish Coat: Sample applied to 2-by-2-inch (50.8-by-50.8-mm) clean glass substrate, cured for 28 days, and showing no growth when tested per ASTM D 3273 and evaluated according to ASTM D 3274.
6. Salt-Spray Resistance: No deleterious affects when tested according to ICC-ES AC219.
7. Tensile Adhesion: No failure in the EIFS, adhesive, base coat, or finish coat when tested per EIMA 101.03.
8. Water Penetration: Sample consisting of 1-inch- (25.4-mm-) thick EIFS mounted on 1/2-inch- (12.7-mm-) thick gypsum board, cured for 28 days, and showing no water penetration into the plane of the base coat to expanded-polystyrene board interface of the test specimen after 15 minutes at 6.24 lbf/sq. ft. (299 Pa) of air pressure difference or 20 percent of positive design wind pressure, whichever is greater, across the specimen during a test period when tested per EIMA 101.02.
9. Water Resistance: Three samples, each consisting of 1-inch- (25.4-mm-) thick EIFS mounted on 1/2-inch- (12.7-mm-) thick gypsum board; cured for 28 days; and showing no cracking, checking, crazing, erosion, rusting, blistering, peeling, or delamination after testing for 14 days per ASTM D 2247.
10. Wind-Driven-Rain Resistance: Resist wind-driven rain according to ICC-ES AC219.
11. Impact Resistance: Sample consisting of 1-inch- (25.4-mm-) thick EIFS when constructed, conditioned, and tested per EIMA 101.86; and meeting or exceeding the following:
  - a. High Impact Resistance: 90 to 150 inch-lb (10.2 to 17 J).
12. Structural Performance Testing: EIFS assembly and components shall comply with ICC-ES AC219 when tested per ASTM E 330.



## 1.5 ACTION SUBMITTALS

- A. Product Data: For each type and component of EIFS indicated.
- B. Samples for Initial Selection: For each type of finish-coat color and texture indicated.
  - 1. Include similar Samples of joint sealants involving color selection.
- C. Samples for Verification: 24-inch- (600-mm-) square panels for each type of finish-coat color and texture indicated, prepared using same tools and techniques intended for actual work including a typical control joint filled with sealant of color selected.
  - 1. Include sealants Samples to verify color selected.

## 1.6 INFORMATIONAL SUBMITTALS

- A. Qualification Data: For Installer.
- B. Manufacturer Certificates: Signed by manufacturers certifying that EIFS and joint sealants comply with requirements.
- C. Material or Product Certificates: For cementitious materials and aggregates and for each insulation and joint sealant, from manufacturer.
- D. Product Test Reports: Based on evaluation of comprehensive tests performed by a qualified testing agency, for each water-/weather-resistive barrier, insulation, reinforcing mesh, joint sealant, and coating.
- E. Compatibility and Adhesion Test Reports: For joint sealants from sealant manufacturer indicating the following:
  - 1. Materials forming joint substrates and joint-sealant backings have been tested for compatibility and adhesion with joint sealants.
  - 2. Interpretation of test results and written recommendations for primers and substrate preparation needed for adhesion.

## 1.7 CLOSEOUT SUBMITTALS

- A. Maintenance Data: For EIFS to include in maintenance manuals.

## 1.8 QUALITY ASSURANCE

- A. Installer Qualifications: An installer who is certified in writing by EIFS manufacturer as qualified to install manufacturer's system using trained workers.
  - 1. Fabricator/Erector Qualifications: Certified in writing by EIFS manufacturer as qualified to fabricate and erect manufacturer's prefabricated panel system using skilled and trained workers.
- B. Source Limitations: Obtain EIFS from single source from single EIFS manufacturer and from sources approved by EIFS manufacturer as compatible with system components.
- C. Fire-Test-Response Characteristics: Provide EIFS and system components with the following fire-test-response characteristics as determined by testing identical EIFS and system components per test method indicated below by UL or another testing and inspecting agency acceptable to authorities having jurisdiction. Identify products with appropriate markings of applicable testing agency.
  - 1. Fire-Resistance Characteristics: Provide materials and construction tested for fire resistance per ASTM E 119.
  - 2. Radiant Heat Exposure: No ignition of EIFS when tested according to NFPA 268.
  - 3. Potential Heat: Acceptable level when tested according to NFPA 259.
  - 4. Surface-Burning Characteristics: Provide insulation board, adhesives, base coats, and finish coats with flame-spread index of 25 or less and smoke-developed index of 450 or less, per ASTM E 84.
- D. Mockups: Build mockups to verify selections made under sample submittals and to demonstrate aesthetic effects and set quality standards for materials and execution and set quality standards for fabrication and installation.
  - 1. Approved mockups may become part of the completed Work if undisturbed at time of Substantial Completion.
- E. Preinstallation Conference: Conduct conference at Project site.

#### 1.9 DELIVERY, STORAGE, AND HANDLING

- A. Deliver materials in original, unopened packages with manufacturers' labels intact and clearly identifying products.
- B. Store materials inside and under cover; keep them dry and protected from weather, direct sunlight, surface contamination, aging, corrosion, damaging temperatures, construction traffic, and other causes.

1. Stack insulation board flat and off the ground.
2. Protect plastic insulation against ignition at all times. Do not deliver plastic insulating materials to Project site before installation time.
3. Complete installation and concealment of plastic materials as rapidly as possible in each area of construction.

#### 1.10 PROJECT CONDITIONS

- A. Weather Limitations: Maintain ambient temperatures above 40 deg F (4.4 deg C) for a minimum of 24 hours before, during, and after adhesives or coatings are applied. Do not apply EIFS adhesives or coatings during rainfall. Proceed with installation only when existing and forecasted weather conditions and ambient outdoor air, humidity, and substrate temperatures permit EIFS to be applied, dried, and cured according to manufacturers' written instructions and warranty requirements.

#### 1.11 COORDINATION

- A. Coordinate installation of EIFS with related Work specified in other Sections to ensure that wall assemblies, including sheathing, flashing, trim, joint sealants, windows, and doors, are protected against damage from the effects of weather, age, corrosion, moisture, and other causes. Do not allow water to penetrate behind flashing and barrier coating of EIFS.

### PART 2 - PRODUCTS

#### 2.1 MANUFACTURERS

- A. Manufacturers: Subject to compliance with requirements, available manufacturers offering products that may be incorporated into the Work include, but are not limited to, the following:
  1. Dryvit Systems, Inc.
  2. Sto Corp.

#### 2.2 MATERIALS

- A. Compatibility: Provide adhesive, fasteners, board insulation, reinforcing meshes, base- and finish-coat systems, sealants, and accessories that are compatible with one another and with substrates and approved for use by EIFS manufacturer for Project.

- B. Exterior Cement Board: Not less than 7/16-inch- (11-mm-) thick, fiber cement board complying with ASTM C 1186, Type A, for exterior applications.
  - 1. Fasteners: Wafer-head or flat-head steel drill screws complying with ASTM C 954, with an organic-polymer coating or other corrosion-protective coating having a salt-spray resistance of more than 500 hours per ASTM B 117.
    - a. Size and Length: As recommended by sheathing manufacturer for type and thickness of sheathing board to be attached.
- C. Primer/Sealer: EIFS manufacturer's standard substrate conditioner designed to seal substrates from moisture penetration and to improve the bond between substrate of type indicated and adhesive used for application of insulation.
- D. Insulation Adhesive: EIFS manufacturer's standard formulation designed for indicated use; compatible with substrate; and complying with one of the following:
  - 1. Job-mixed formulation of portland cement complying with ASTM C 150, Type I, and polymer-based adhesive specified for base coat.
  - 2. Factory-blended dry formulation of portland cement, dry polymer admixture, and fillers specified for base coat.
  - 3. Factory-mixed noncementitious formulation designed for adhesive attachment of insulation to substrates of type indicated, as recommended by EIFS manufacturer.
- E. Molded, Rigid Cellular Polystyrene Board Insulation: Comply with ASTM C 578, Type I; EIFS manufacturer's requirements; and EIMA's "EIMA Guideline Specification for Expanded Polystyrene (EPS) Insulation Board" for most stringent requirements for material performance and qualities of insulation, including dimensions and permissible variations, and the following:
  - 1. Aging: Before cutting and shipping, age insulation in block form by air drying for not less than six weeks or by another method approved by EIMA that produces equivalent results.
  - 2. Flame-Spread and Smoke-Developed Indexes: 25 and 450 or less, respectively, per ASTM E 84.
  - 3. Dimensions: Provide insulation boards not more than 24 by 48 inches (610 by 1219 mm) and in thickness indicated, but not more than 4 inches (102 mm) thick or less than thickness allowed by ASTM C 1397.
  - 4. Foam Shapes: Provide with profiles and dimensions indicated on Drawings.
- F. Reinforcing Mesh: Balanced, alkali-resistant, open-weave, glass-fiber mesh treated for compatibility with other EIFS materials, made from continuous multiend strands with retained mesh tensile strength of not less than 120 lbf/in. (21 dN/cm) per ASTM E 2098; complying with ASTM D 578 and the following:

1. High-Impact Reinforcing Mesh: Not less than 15 oz./sq. yd. (509 g/sq. m).
  2. Strip Reinforcing Mesh: Not less than 3.75 oz./sq. yd. (127 g/sq. m).
  3. Detail Reinforcing Mesh: Not less than 4.0 oz./sq. yd. (136 g/sq. m).
  4. Corner Reinforcing Mesh: Not less than 7.2 oz./sq. yd. (244 g/sq. m).
- G. Base-Coat Materials: EIFS manufacturer's standard mixture complying with one of the following:
1. Job-mixed formulation of portland cement complying with ASTM C 150, Type I, white or natural color; and manufacturer's standard polymer-emulsion adhesive designed for use with portland cement.
  2. Job-combined formulation of manufacturer's standard polymer-emulsion adhesive and manufacturer's standard dry mix containing portland cement.
  3. Factory-blended dry formulation of portland cement, dry polymer admixture, and inert fillers to which only water is added at Project site.
  4. Factory-mixed noncementitious formulation of polymer-emulsion adhesive and inert fillers that is ready to use without adding other materials.
- H. Waterproof Adhesive/Base-Coat Materials: EIFS manufacturer's standard waterproof formulation and complying with one of the following:
1. Job-mixed formulation of portland cement complying with ASTM C 150, Type I, white or natural color; and manufacturer's standard polymer-emulsion adhesive designed for use with portland cement.
  2. Job-combined formulation of manufacturer's standard polymer-emulsion adhesive and manufacturer's standard dry mix containing portland cement.
- I. Primer: EIFS manufacturer's standard factory-mixed, elastomeric-polymer primer for preparing base-coat surface for application of finish coat.
- J. Finish-Coat Materials: EIFS manufacturer's standard acrylic-based coating with enhanced mildew resistance complying with the following:
1. Factory-mixed formulation of polymer-emulsion binder, colorfast mineral pigments, sound stone particles, and fillers.
  2. Sealer: Manufacturer's waterproof, clear acrylic-based sealer for protecting finish coat.
  3. Colors: To Match Existing.
- K. Water: Potable.
- L. Mechanical Fasteners: EIFS manufacturer's standard corrosion-resistant fasteners consisting of thermal cap, standard washer and shaft attachments, and fastener indicated

below; selected for properties of pullout, tensile, and shear strength required to resist design loads of application indicated; capable of pulling fastener head below surface of insulation board; and of the following description:

1. For attachment to light-gage steel framing members not less than 0.0179 inch (0.45 mm) in thickness, provide steel drill screws complying with ASTM C 1002.
  2. For attachment, provide manufacturer's standard fasteners suitable for substrate.
- M. Trim Accessories: Type as designated or required to suit conditions indicated and to comply with EIFS manufacturer's written instructions; manufactured from UV-stabilized PVC; and complying with ASTM D 1784, manufacturer's standard Cell Class for use intended, and ASTM C 1063.
1. Casing Bead: Prefabricated, one-piece type for attachment behind insulation, of depth required to suit thickness of coating and insulation, with face leg perforated for bonding to coating and back leg.
  2. Expansion Joint: Prefabricated, one-piece V profile; designed to relieve stress of movement.
  3. Window Sill Flashing: Prefabricated type for both flashing and sloping sill over framing beneath windows; with end and back dams; designed to direct water to exterior.

### 2.3 ELASTOMERIC SEALANTS

- A. Elastomeric Sealant Products: Provide EIFS manufacturer's listed and recommended chemically curing, elastomeric sealant that is compatible with joint fillers, joint substrates, and other related materials, and complies with requirements for products and testing indicated in ASTM C 1481 and with requirements in Division 07 Section "Joint Sealants" for products corresponding to description indicated below:
1. Single-component, nonsag, neutral-curing silicone sealant.
- B. Sealant Color: As selected by Architect from manufacturer's full range.

### 2.4 MIXING

- A. General: Comply with EIFS manufacturer's requirements for combining and mixing materials. Do not introduce admixtures, water, or other materials except as recommended by EIFS manufacturer. Mix materials in clean containers. Use materials within time period specified by EIFS manufacturer or discard.

## PART 3 - EXECUTION

### 3.1 EXAMINATION

- A. Examine substrates, areas, and conditions, with Installer present, for compliance with requirements for installation tolerances and other conditions affecting performance of EIFS.
- B. Examine roof edges, wall framing, flashings, openings, substrates, and junctures at other construction for suitable conditions where EIFS will be installed.
- C. Proceed with installation only after unsatisfactory conditions have been corrected.
  - 1. Begin coating application only after surfaces are dry.
  - 2. Application of coating indicates acceptance of surfaces and conditions.

### 3.2 PREPARATION

- A. Protect contiguous work from moisture deterioration and soiling caused by application of EIFS. Provide temporary covering and other protection needed to prevent spattering of exterior finish coats on other work.
- B. Protect EIFS, substrates, and wall construction behind them from inclement weather during installation. Prevent penetration of moisture behind EIFS and deterioration of substrates.
- C. Prepare and clean substrates to comply with EIFS manufacturer's written instructions to obtain optimum bond between substrate and adhesive for insulation.
  - 1. Concrete Substrates: Provide clean, dry, neutral-pH substrate for insulation installation. Verify suitability of substrate by performing bond and moisture tests recommended by EIFS manufacturer.

### 3.3 EXTERIOR CEMENT-BOARD INSTALLATION

- A. Exterior Cement Board: Install on metal framing to comply with cement-board manufacturer's written instructions and evaluation report acceptable to authorities having jurisdiction. Install board with steel drill screws spaced no more than 8 inches (203 mm) o.c. along framing with perimeter fasteners at least 3/8 inch (9.6 mm) but less than 5/8 inch (15.9 mm) from edges of boards.

### 3.4 EIFS INSTALLATION, GENERAL

- A. Comply with ASTM C 1397 and EIFS manufacturer's written instructions for installation of EIFS as applicable to each type of substrate indicated.

### 3.5 SUBSTRATE PROTECTION APPLICATION

- A. Primer/Sealer: Apply over gypsum sheathing substrates to protect substrates from degradation and where required by EIFS manufacturer for improving adhesion of insulation to substrate.
- B. Waterproof Adhesive/Base Coat: Apply over window sills to protect substrates from degradation.
- C. Flexible-Membrane Flashing: Install over weather-resistive barrier, applied and lapped to shed water; seal at openings, penetrations, terminations, and where indicated by EIFS manufacturer's written instructions to protect wall assembly from degradation. Prime substrates, if required, and install flashing to comply with EIFS manufacturer's written instructions and details.

### 3.6 TRIM INSTALLATION

- A. Trim: Apply trim accessories at perimeter of EIFS, at expansion joints, at window sills, and elsewhere as indicated, according to EIFS manufacturer's written instructions. Coordinate with installation of insulation.
  - 1. Drip Screed/Track: Use at bottom edges of EIFS unless otherwise indicated.
  - 2. Window Sill Flashing: Use at windows unless otherwise indicated.
  - 3. Expansion Joint: Use where indicated on Drawings.
  - 4. Casing Bead: Use at other locations.

### 3.7 INSULATION INSTALLATION

- A. Board Insulation: Adhesively attach insulation to substrate in compliance with ASTM C 1397, EIFS manufacturer's written instructions, and the following:
  - 1. Apply adhesive to insulation by notched-trowel method in a manner that results in coating the entire surface of sheathing with adhesive once insulation is adhered to sheathing unless EIFS manufacturer's written instructions specify using primer/sealer with ribbon-and-dab method. Apply adhesive to a thickness of not less than 1/4 inch



- (6.4 mm) for factory mixed and not less than 3/8 inch (9.6 mm) for field mixed, measured from surface of insulation before placement.
2. Press and slide insulation into place. Apply pressure over the entire surface of insulation to accomplish uniform contact, high initial grab, and overall level surface.
  3. Allow adhered insulation to remain undisturbed for period recommended by EIFS manufacturer, but not less than 24 hours, beginning rasping and sanding insulation, or applying base coat and reinforcing mesh.
  4. Apply insulation over dry substrates in courses with long edges of boards oriented horizontally.
  5. Begin first course of insulation from a level base line and work upward.
  6. Begin first course of insulation from screed/track and work upward. Work from perimeter casing beads toward interior of panels if possible.
  7. Stagger vertical joints of insulation boards in successive courses to produce running bond pattern. Locate joints so no piece of insulation is less than 12 inches (300 mm) wide or 6 inches (150 mm) high. Offset joints not less than 6 inches (150 mm) from corners of window and door openings.
    - a. Adhesive Attachment: Offset joints of insulation not less than 6 inches (150 mm) from horizontal and 4 inches (100 mm) from vertical joints in sheathing.
  8. Interlock ends at internal and external corners.
  9. Abut insulation tightly at joints within and between each course to produce flush, continuously even surfaces without gaps or raised edges between boards. If gaps greater than 1/16 inch (1.6 mm) occur, fill with insulation cut to fit gaps exactly; insert insulation without using adhesive or other material.
  10. Cut insulation to fit openings, corners, and projections precisely and to produce edges and shapes complying with details indicated.
  11. Rasp or sand flush entire surface of insulation to remove irregularities projecting more than 1/16 inch (1.6 mm) from surface of insulation and to remove yellowed areas due to sun exposure; do not create depressions deeper than 1/16 inch (1.6 mm).
  12. Interrupt insulation for expansion joints where indicated.
  13. Form joints for sealant application by leaving gaps between adjoining insulation edges and between insulation edges and dissimilar adjoining surfaces. Make gaps wide enough to produce joint widths indicated after encapsulating joint substrates with base coat and reinforcing mesh.
  14. Form joints for sealant application with back-to-back casing beads for joints within EIFS and with perimeter casing beads at dissimilar adjoining surfaces. Make gaps between casing beads and between perimeter casing beads and adjoining surfaces of width indicated.
  15. After installing insulation and before applying reinforcing mesh, fully wrap board edges with strip reinforcing mesh. Cover edges of board and extend encapsulating mesh not less than 2-1/2 inches (64 mm) over front and back face unless otherwise indicated on Drawings.

16. Coordinate installation of flashing and insulation to produce wall assembly that does not allow water to penetrate behind flashing and EIFS protective-coating lamina.
- B. Expansion Joints: Install at locations indicated, where required by EIFS manufacturer, and as follows:
1. At expansion joints in substrates behind EIFS.
  2. Where EIFS adjoin dissimilar substrates, materials, and construction, including other EIFS.
  3. Where EIFS manufacturer requires joints in long continuous elevations.

### 3.8 BASE-COAT INSTALLATION

- A. Base Coat: Apply to exposed surfaces of insulation in minimum thickness recommended in writing by EIFS manufacturer, but not less than 1/16-inch (1.6-mm) dry-coat thickness.
- B. Reinforcing Mesh: Embed type indicated below in wet base coat to produce wrinkle-free installation with mesh continuous at corners and overlapped not less than 2-1/2 inches (64 mm) or otherwise treated at joints to comply with ASTM C 1397 and EIFS manufacturer's written instructions. Do not lap reinforcing mesh within 8 inches (204 mm) of corners. Completely embed mesh, applying additional base-coat material if necessary, so reinforcing-mesh color and pattern are not visible.
1. High-impact reinforcing mesh.
- C. Additional Reinforcing Mesh: Apply strip reinforcing mesh around openings extending 4 inches (100 mm) beyond perimeter. Apply additional 9-by-12-inch (230-by-300-mm) strip reinforcing mesh diagonally at corners of openings (re-entrant corners). Apply 8-inch- (200-mm-) wide strip reinforcing mesh at both inside and outside corners unless base layer of mesh is lapped not less than 4 inches (100 mm) on each side of corners.
1. At aesthetic reveals, apply strip reinforcing mesh not less than 8 inches (200 mm) wide.
  2. Embed strip reinforcing mesh in base coat before applying first layer of reinforcing mesh.

### 3.9 FINISH-COAT INSTALLATION

- A. Primer: Apply over dry base coat according to EIFS manufacturer's written instructions.
- B. Finish Coat: Apply over dry or primed base coat, maintaining a wet edge at all times for uniform appearance, in thickness required by EIFS manufacturer to produce a uniform

finish of color and texture matching approved sample and free of cold joints, shadow lines, and texture variations.

1. Texture: To Match Existing.

### 3.10 INSTALLATION OF JOINT SEALANTS

- A. Prepare joints and apply sealants, of type and at locations indicated, to comply with applicable requirements in Division 07 Section "Joint Sealants" and in ASTM C 1481.
  1. Apply joint sealants after base coat has cured but before applying finish coat.
  2. Clean surfaces to receive sealants to comply with indicated requirements and EIFS manufacturer's written instructions.
  3. Apply primer recommended in writing by sealant manufacturer for surfaces to be sealed.
  4. Install sealant backing to control depth and configuration of sealant joint and to prevent sealant from adhering to back of joint.
  5. Apply masking tape to protect areas adjacent to sealant joints. Remove tape immediately after tooling joints, without disturbing joint seal.
  6. Recess sealant sufficiently from surface of EIFS so an additional sealant application, including cylindrical sealant backing, can be installed without protruding beyond EIFS surface.

END OF SECTION 072413

NOTES

|                              |                  |
|------------------------------|------------------|
| <b>REVISION INFORMATION:</b> |                  |
| REV. TO DETAIL/SHEET:        | 2/A4.1           |
| REV. DATE:                   | 11 FEB 2010      |
| REV. No:                     | 1                |
| DESCRIPTION:                 | ADDED TAG 8/A5.1 |
| ISSUED WITH:                 | ADDENDUM #4      |



10,720  
PROJECT CODE

11 FEBRUARY 2010  
DATE

ADDENDUM #4  
REVISED

|   |   |
|---|---|
| △ | △ |
| △ | △ |
| △ | △ |
| △ | △ |
| △ | △ |
| △ | △ |

**DR. B.L. PERRY BRANCH  
LIBRARY EXPANSION**  
-  
**SUPPLEMENTARY DRAWING**  
Tallahassee Florida

# SD-1

225 SOUTH ADAMS ST., TALLAHASSEE, FLORIDA 32301  
PHONE 850 224-6301 FAX 850 561-6978

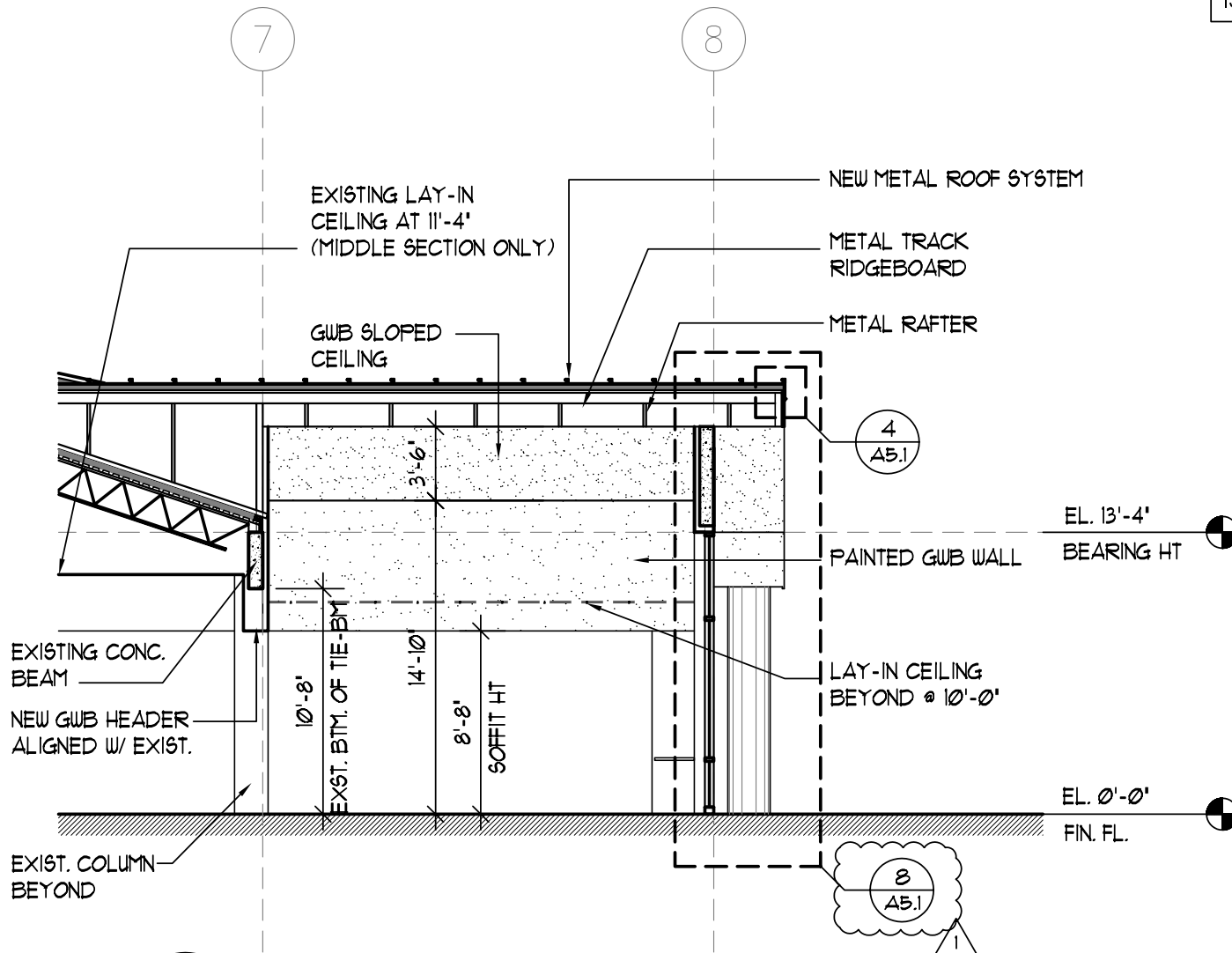

**2 BUILDING SECTION**  
**A4.1** SCALE 1/8"=1'-0"

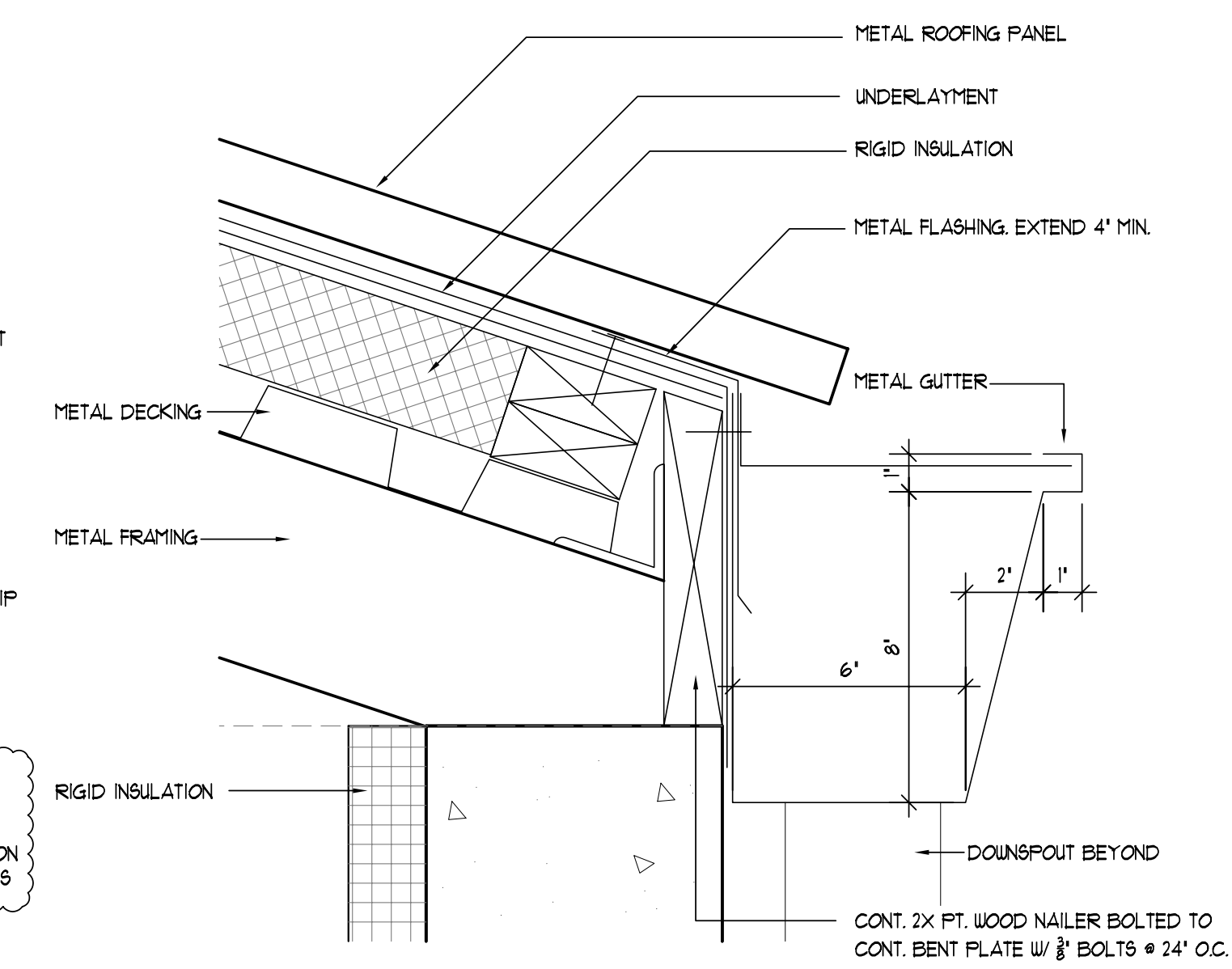
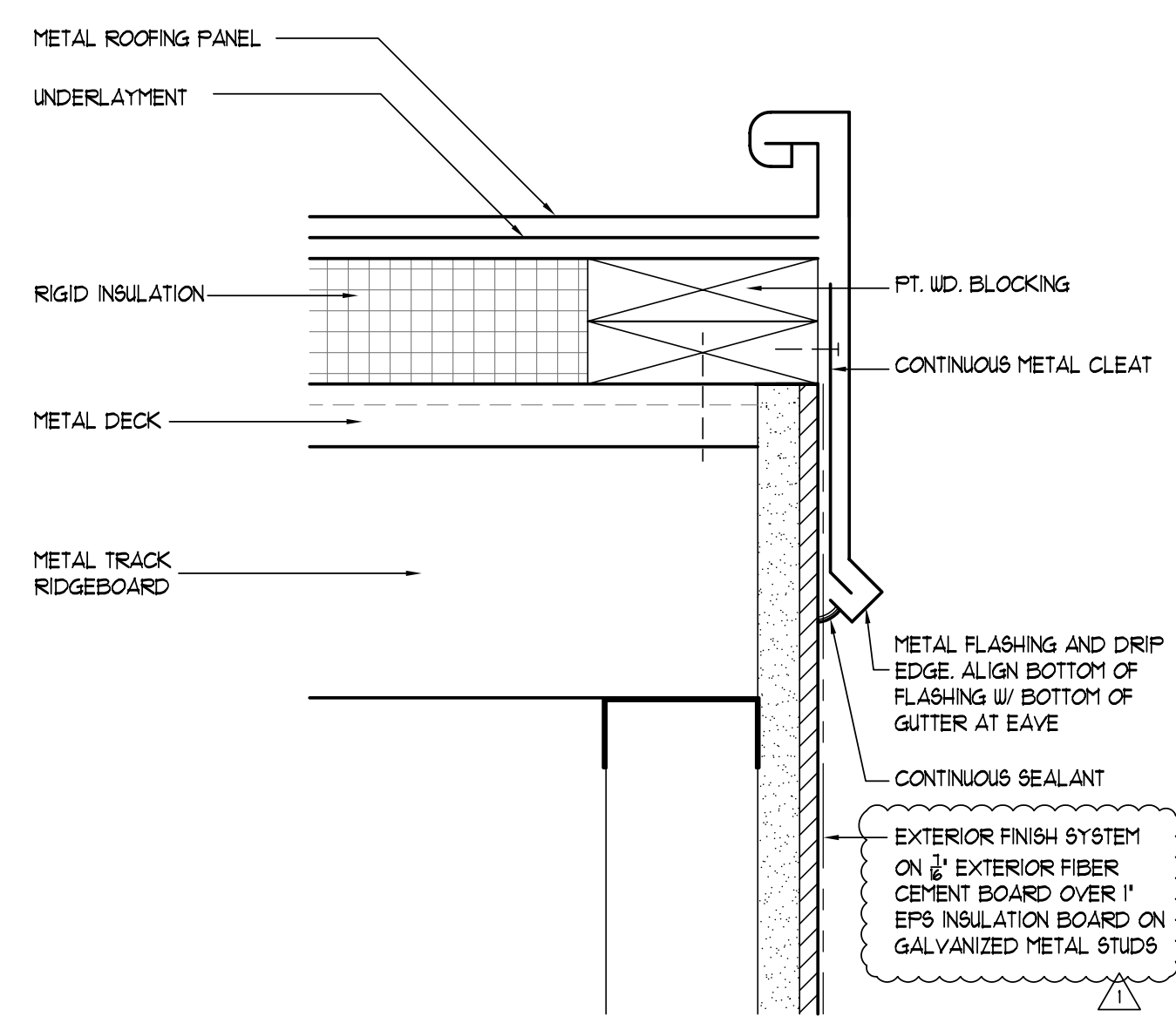
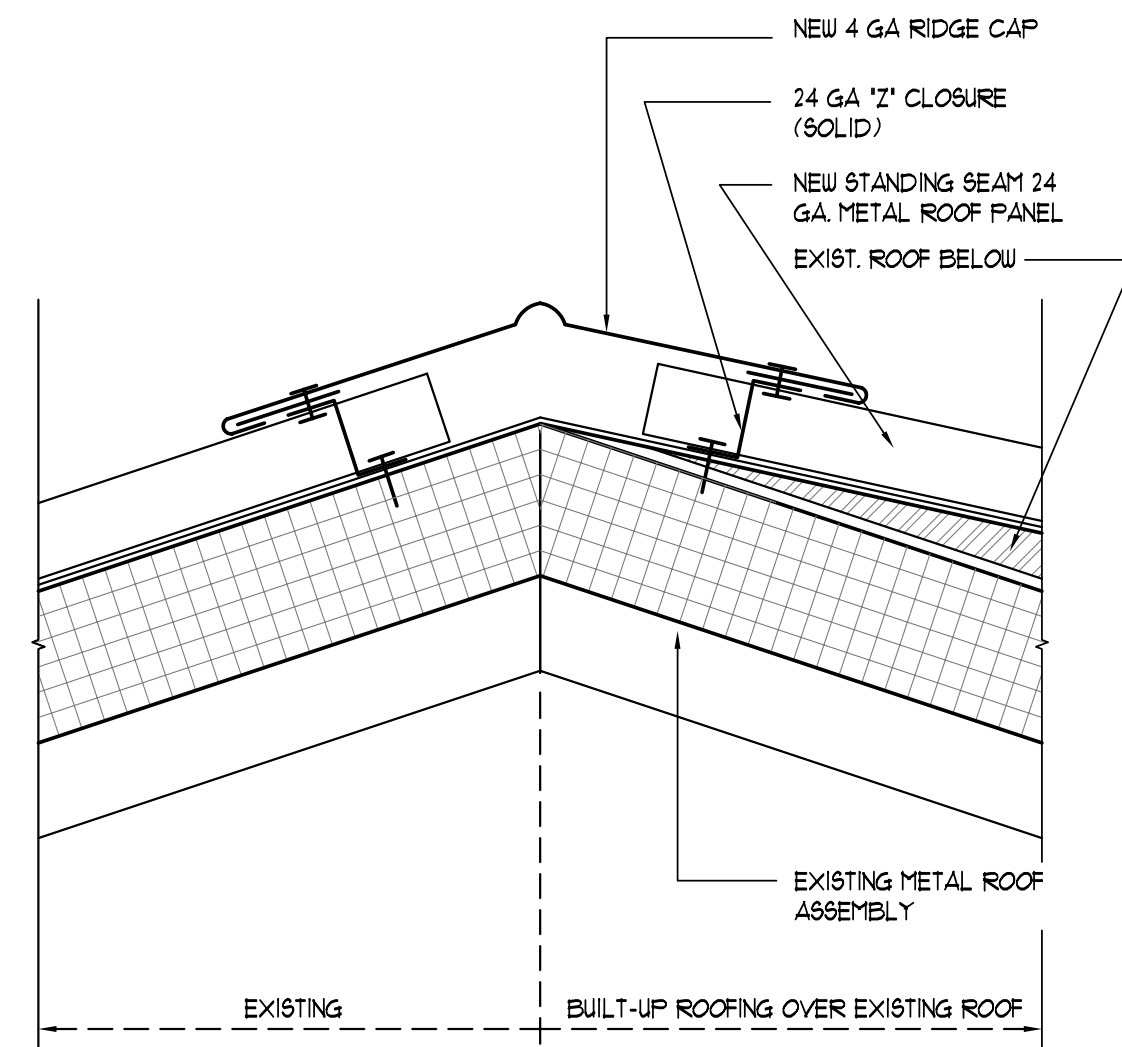
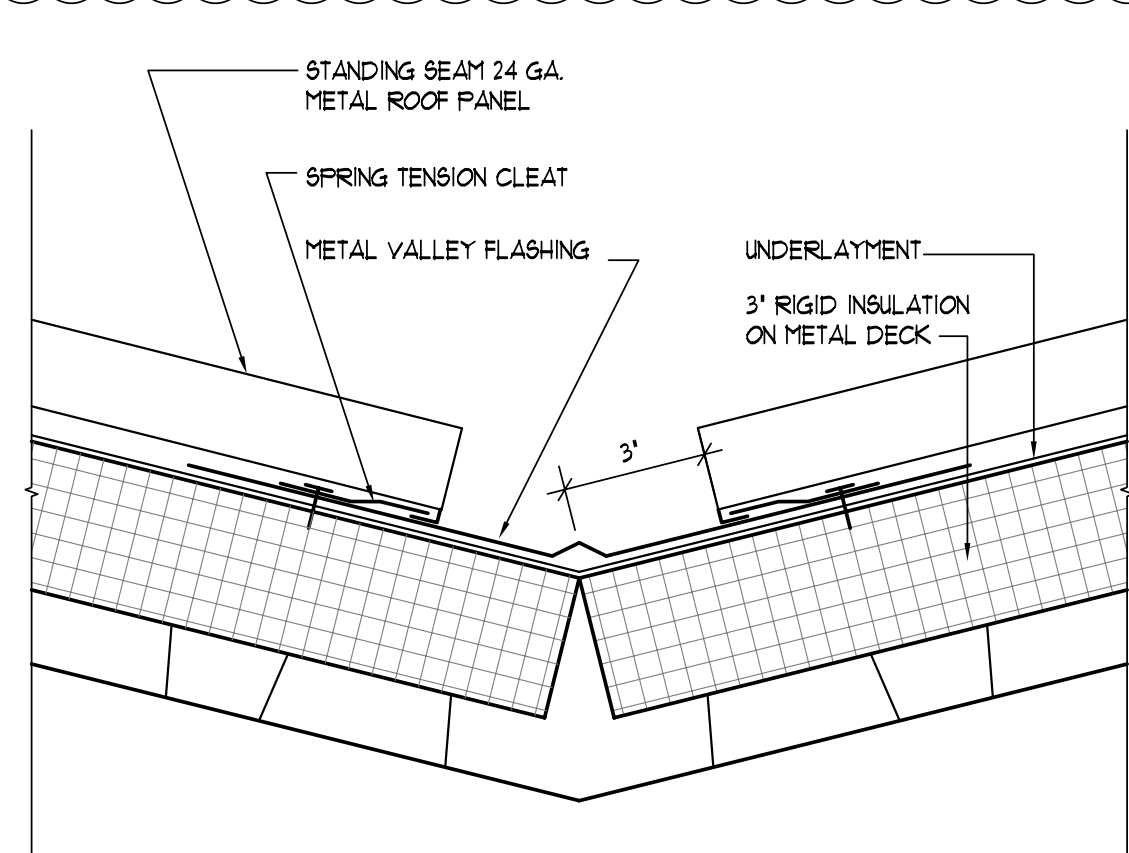
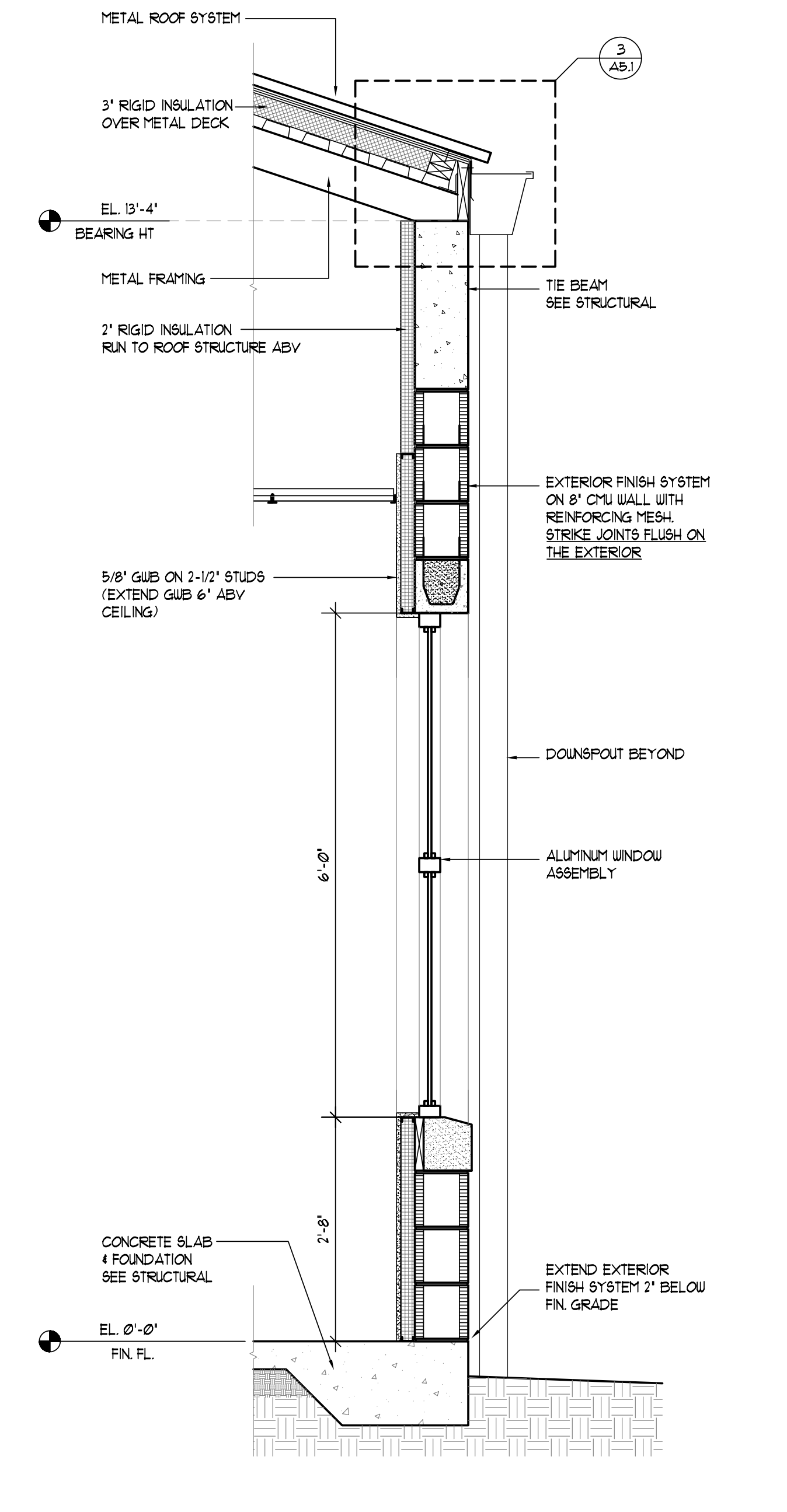
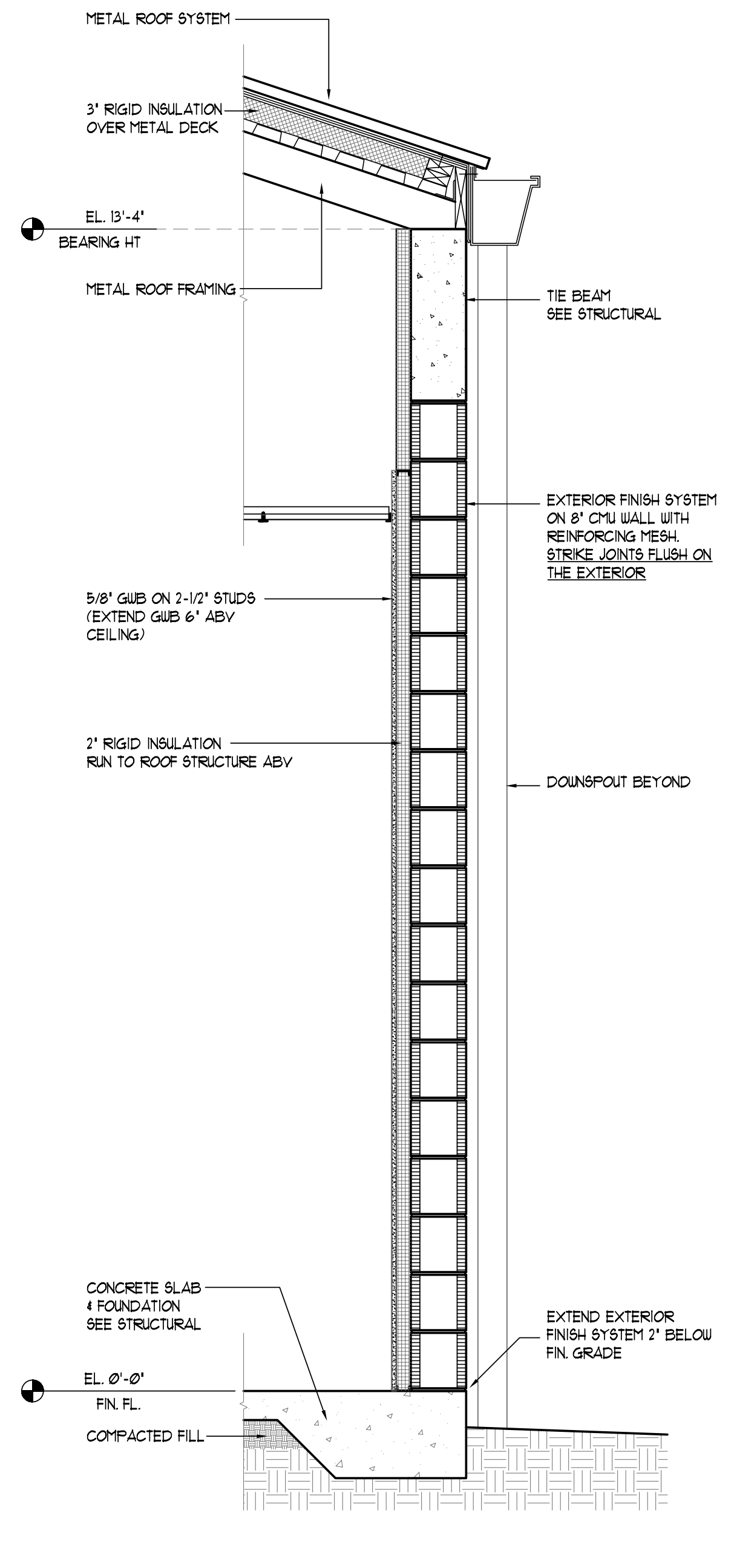
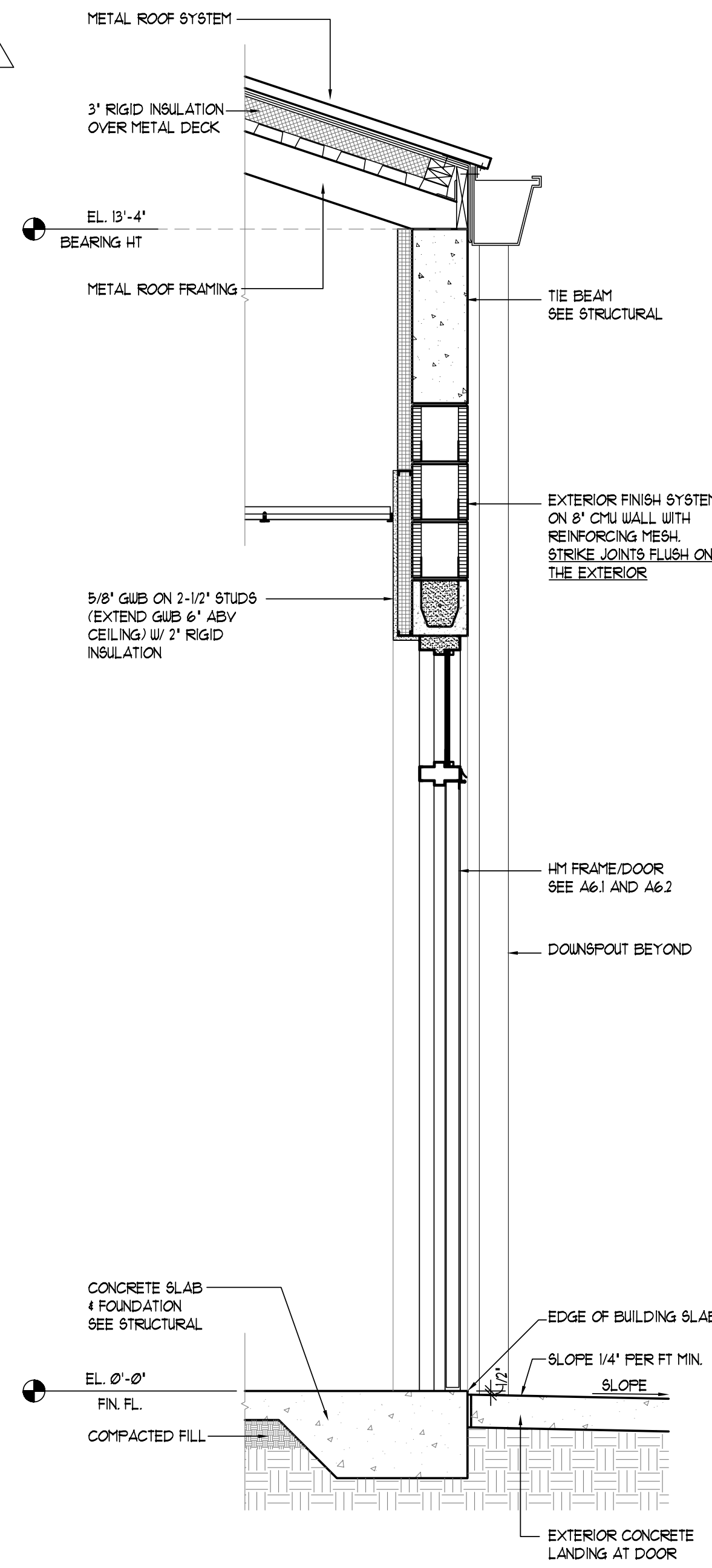
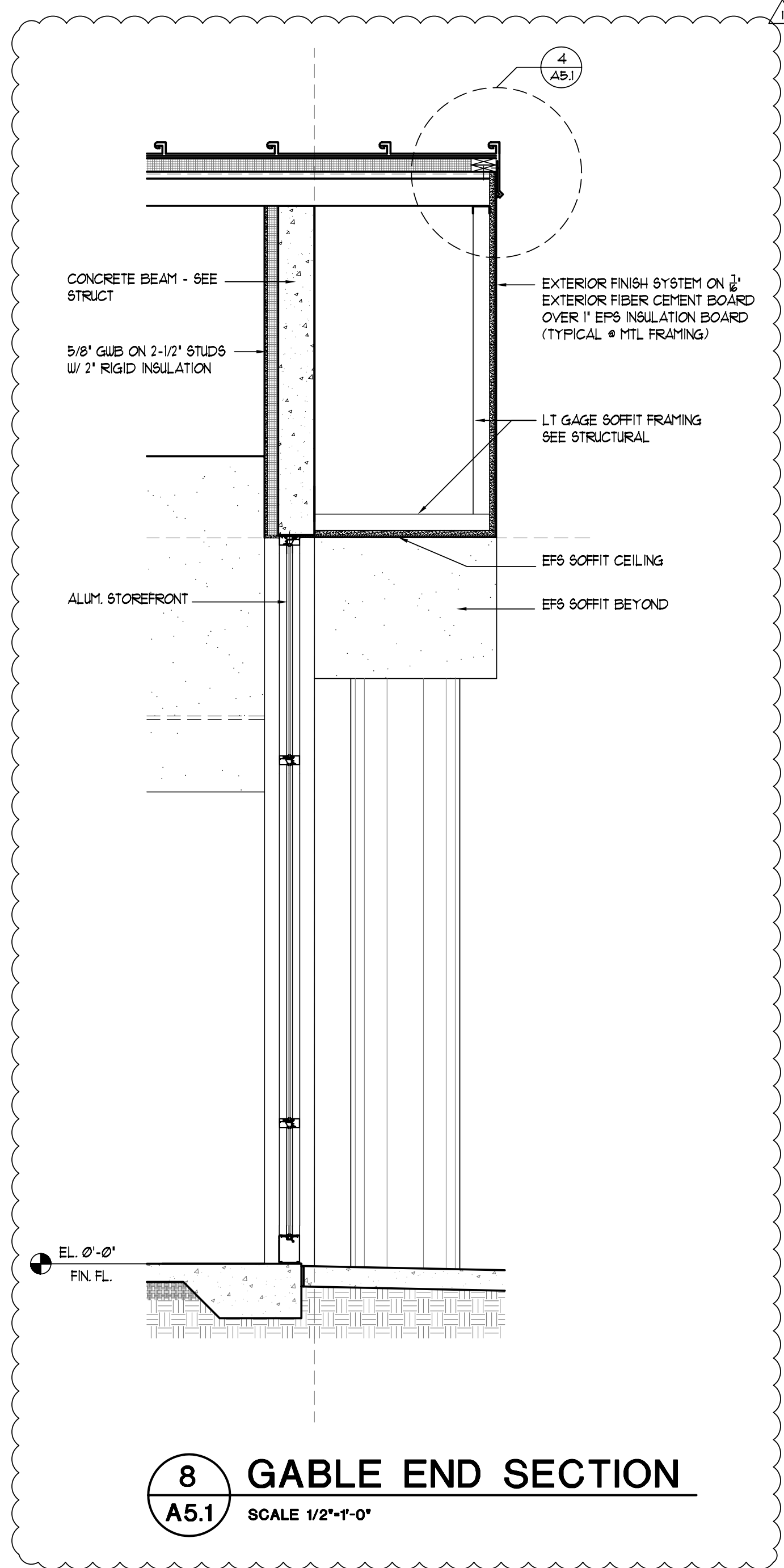

10,720 PROJECT CODE

15 DECEMBER 2009 DATE

CONSTRUCTION DOCUMENTS

| NO. | DATE        | DESCRIPTION |
|-----|-------------|-------------|
| 1   | 11 FEB 2010 | ADDENDUM    |
| 2   |             |             |
| 3   |             |             |
| 4   |             |             |
| 5   |             |             |
| 6   |             |             |
| 7   |             |             |
| 8   |             |             |
| 9   |             |             |
| 10  |             |             |

DR. B.L. PERRY BRANCH LIBRARY EXPANSION

WALL SECTIONS & DETAILS Tallahassee Florida

A5.1

225 SOUTH ADAMS ST., TALLAHASSEE, FLORIDA 32301  
PHONE 850 224-6301 FAX 850 561-6978